

LED LIGHTING - NOXEL LED HIGH BAY



No more Heating, LED High Bays

Less Heat, More Comfortable

LEDs especially High Bay do not emit as much heat as conventional HPS (High Pressure Sodium) High Bays. So no more worries on the lights getting too hot and start burning the top of the roof. The LED high bay also makes people working under the light more comfortable. Safety yet comfortable.

Maximum Throw, Even Lights

We engineered our High Bay Luminaire for maximum throw, either design with lens or without lens to suit the current application in question. The end result, end users will get the same level of brightness but more even lighting effect.

Applications:

- Industrial Buildings
- Warehouse
- High Ceiling Area

Model:

NX-HB-100W: 100W/9000lm

NX-HB-150W: 150W/12500lm

Thinking of lights the different way. Save more, do more with LEDs.

NOXEL LED. *Light of the future.*

NOXEL[®]
LED LUMINAIRES

WWW.NOXEL.COM



NOXEL LED STREET LIGHT

IP65

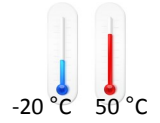

Module Powered by: **CREE**

Specification

Model Code	Wattage	Luminous Flux	Beam Angle (°)	Diameter (mm)	Height (mm)	Weight (kg)
NX-HB-100W-01	100W	9000	60°	100	280	4.5
NX-HB-150W-01	150W	12500	60°	100	370	5

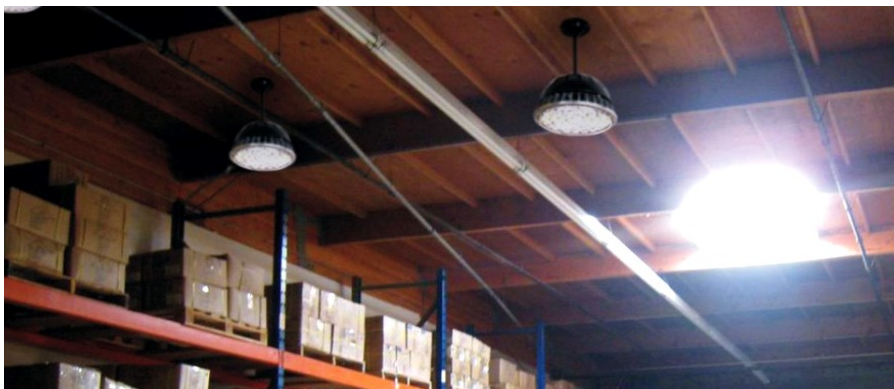
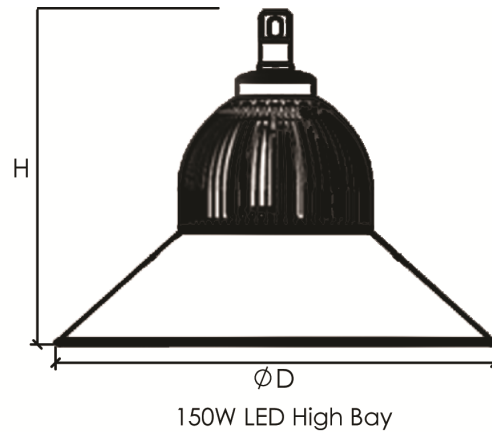
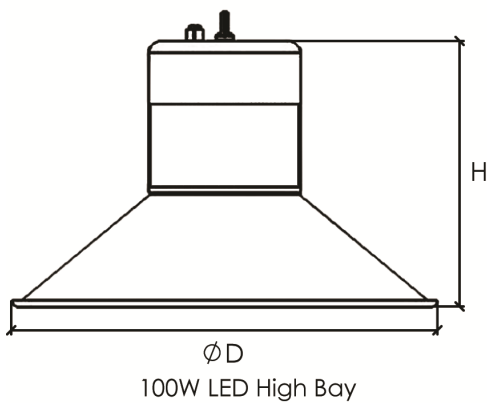

Non Standard Customizable Features

- S01—Without Reflector
- S02—Without Lens

NOXEL[®]
LED LUMINAIRES

WWW.NOXEL.COM